



The 6416Y2 A-Net® Interface Card is a 16-channel input/output expansion card for Yamaha® products supporting Yamaha's mini-YGDAL (MY) format. Compatible products include most Yamaha digital mixing consoles as well as Digital Mix Engine devices. The Y2 A-Net card is compatible with all Aviom Pro64® Series products, and, with an ASI A-Net Systems Interface module, can also be used with Pro16® Series output products, such as the industry standard A-16II Personal Mixer.

The Y2 A-Net card supports up to 16 channels in and 16 channels out simultaneously, depending on the Yamaha host product's capacity and the selected system sample rate. Multiple cards may be used in a single host device, providing up to 64 channels in and 64 channels out, simultaneously. Inputs and outputs may be assigned to one of four A-Net network slot banks, while input channels may be individually activated as needed.

In addition, the Y2 A-Net card supports two interface paths to the Pro64 network's innovative Virtual Data Cables™. The card features a front-panel DB9 connector for either RS-232 or RS-422 data. In certain Yamaha digital consoles, control data may also be routed to the card through the backplane. Internal DIP switches allow these data paths to be configured for a variety of uses, including passing control data for remote Yamaha microphone preamps.

Pro64 audio networks featuring Y2 A-Net cards can be configured to slave to a host console or to pass clock information to the console through the card slot backplane. All Pro64 products feature Aviom's exclusive clock management algorithms, ensuring pristine clocking throughout a network, including console-to-console communications.

Y2 A-Net Cards can be connected serially or in parallel, using a Pro64 Merger Hub such as the MH10f.

PRODUCT HIGHLIGHTS

- Up to 16 channels in and 16 channels out simultaneously
- Variable sample rates: 44.1/48kHz or 88.2/96kHz
- Robust clocking allows simple console-to-console digital connections
- Stereo Link per channel pair for Pro16 Personal Mixers
- RS-232/RS-422 Virtual Data Cable I/O (compatible with Yamaha remote control protocol)
- Multiple cards per console
- Compatible with Yamaha mini-YGDAL card slot

TECHNICAL SPECIFICATIONS

Channels	Up to 16 inputs and 16 outputs simultaneously	
Interface Format	Yamaha® mini-YGDAL Expansion Card supports 8- and 16-channel modes	
Sample Rates	1x: 39.7–52kHz; 2x: 79.4–104kHz	24-bit resolution
Maximum Ambient Temperature	50°C	
Virtual Data Cables	RS-232/RS-422 DB9 connector; DIP switch configuration	
	Control data from backplane may also be routed to VDCs; DIP switch configuration	

A-Net	2 EtherCon® RJ45 connectors
A-Net Cable Length	400 feet (120 meters) between devices
Latency	Digital input to digital output, through the Pro64 network: <460µs
Power Supply	+3.3V, +5V, +15V supplied by Yamaha host device
Dimensions	4.75" w x 6.25" d x 1.5" h (120.7 x 158.8 x 38.1 mm)
Weight	0.8 pounds (0.36 kilos)
<i>All Aviom products are designed and manufactured in the U.S.A.</i>	

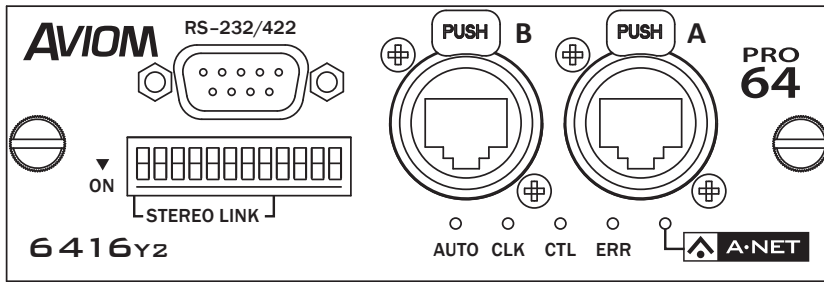

FRONT PANEL FEATURES

- Stereo Link DIP switches
- VDC I/O for RS-232/422
- Dual A-Net ports
- Auto Mode LED
- Clock Master and Control Master LEDs
- Error LED

INTERNAL DIP SWITCHES

- A-Net Slot bank select (inputs)
- A-Net Slot bank select (outputs)
- Input channel activation
- Network mode and port select
- VDC Slot select
- VDC data rate and configuration

6416Y2 BLOCK DIAGRAM

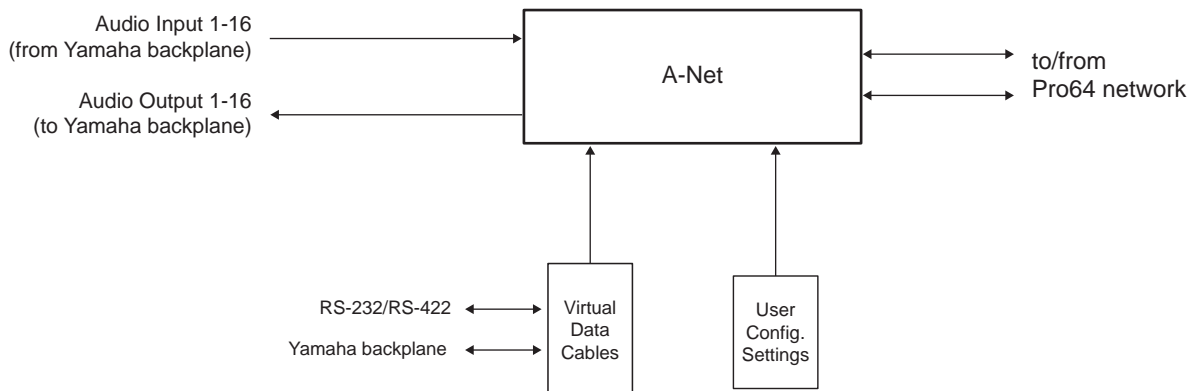

ARCHITECTURAL SPECIFICATION

The Aviom 6416Y2 A-Net Interface Card shall provide up to sixteen channels of digital audio inputs and up to 16 channels of digital audio outputs transmitted digitally via a Pro64® A-Net® network. It shall provide full-bandwidth, high-quality audio by employing the A-Net audio transmission protocol and shall support sample rates from 39.7kHz to 52kHz and 79.4kHz to 104kHz.

Channel assignments shall be configured and routed from within a Yamaha digital mixing console, according to the limitations of the Yamaha product. The card shall meet the specifications of the Yamaha mini-YGDAL expansion card format.

Front-panel features shall include one 12-position DIP switch block and LED indicators for network mode, Clock Master, Control Master, Error, and A-Net Active. It shall employ dual EtherCon® RJ45 connectors for the A-Net digital

signal connections and provide one DB9 connector, selectable for RS-232 or RS-422 data.

Internal DIP switches shall be provided for A-Net Slot bank selection, network mode, input channel activation, and Virtual Data Cable™ configuration.

The rear panel shall have a multipin connector to interface with the Yamaha expansion port connectors, consistent with the mini-YGDAL specification. Power shall be supplied to the card by the Yamaha host device.

Its dimensions shall be 4.75 inches wide, 6.25 inches deep, and 1.5 inches high. Its net weight shall be 0.8 pounds, and its front panel shall be finished in blue. The unit shall be Aviom Incorporated model 6416Y2.