

# **Q-SUB**

## **Manual (2.2 EN)**



## Symbols on the equipment

Please refer to the information in the operating manual.

**WARNING!**  
**Dangerous voltage!**

## Contents

|  |          |
|--|----------|
| <b>Safety precautions.....</b>                 | <b>3</b> |
| Information regarding use of loudspeakers..... | 3        |
| <b>Q-SUB.....</b>                              | <b>4</b> |
| Connections.....                               | 4        |
| Operation with D6 or D12.....                  | 5        |
| Operation with E-PAC.....                      | 5        |
| Technical specifications.....                  | 6        |
| Q-SUB and Q1 cabinets.....                     | 7        |
| Q-SUB and Q7 cabinets.....                     | 7        |
| <b>Manufacturer's declarations.....</b>        | <b>8</b> |
| EU conformity of loudspeakers (CE symbol)..... | 8        |
| WEEE Declaration (Disposal).....               | 8        |

## General Information

Q-SUB Manual

Version 2.2 EN, 03/2008, D2042.E.02

Copyright © 2008 by d&b audiotechnik GmbH; all rights reserved.

Keep this manual with the product or in a safe place so that it is available for future reference.

When reselling this product, handout this manual to the new customer.

If you supply d&b products, please draw the attention of your customers to this manual. Enclose the relevant manuals with the systems. If you require additional manuals for this purpose, you can order them from d&b.

d&b audiotechnik GmbH  
Eugen-Adolff-Strasse 134, D-71522 Backnang, Germany  
Telephone +49-7191-9669-0, Fax +49-7191-95 00 00  
E-mail: docadmin@dbaudio.com, Internet: www.dbaudio.com

## Safety precautions



### WARNING!

#### Information regarding use of loudspeakers

Never stand in the immediate vicinity of loudspeakers driven at a high level. Professional loudspeaker systems are capable of causing a sound pressure level detrimental to human health. Seemingly non-critical sound levels (from approx. 95 dB SPL) can cause hearing damage if people are exposed to it over a long period.

In order to prevent accidents when deploying loudspeakers on the ground or when flown, please take note of the following:

When setting up the loudspeakers or loudspeaker stands, make sure they are standing on a firm surface. If you place several systems on top of one another, use straps to secure them against movement.

Only use accessories which have been tested and approved by d&b for assembly and mobile deployment. Pay attention to the correct application and maximum load capacity of the accessories as detailed in our specific "Mounting instructions" or in our "Flying system and Rigging manuals".

Ensure that all additional hardware, fixings and fasteners used for installation or mobile deployment are of an appropriate size and load safety factor. Pay attention to the manufacturers' instructions and to the relevant safety guidelines.

Regularly check the loudspeaker housings and accessories for visible signs of wear and tear, and replace them when necessary.

Regularly check all load bearing bolts in the mounting devices.

### CAUTION!

Loudspeakers produce a static magnetic field even if they are not connected or are not in use. Therefore make sure when erecting and transporting loudspeakers that they are nowhere near equipment and objects which may be impaired or damaged by an external magnetic field. Generally speaking, a distance of 0.5 m (1.5 ft) from magnetic data carriers (floppy disks, audio and video tapes, bank cards, etc.) is sufficient; a distance of more than 1 m (3 ft) may be necessary with computer and video monitors.

## Q-SUB

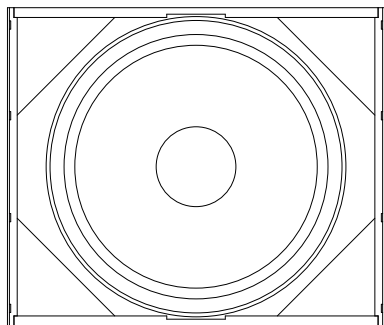

**Fig. 1: Q-SUB**

The Q-SUB is the subwoofer for the Q-Series. It can be used to supplement Q1 and Q7 cabinets in various combinations, either flown or ground stacked. The Q-SUB cabinet is an actively driven bass-reflex design housing a long excursion 18" driver, its frequency response extending from 40 Hz to 130 Hz.

The Q-SUB cabinet is constructed from marine plywood and has an impact resistant paint finish. The front of the loudspeaker cabinet is protected by a rigid metal grill, covered with a replaceable acoustically transparent foam. The cabinet incorporates a pair of handles, and mounted on the rear panel are two EP5 or NL4 connectors wired in parallel and four heavy duty wheels. An M20 threaded flange in the top panel accepts the d&b Z5013 Loudspeaker stand for the deployment of full range cabinets.

The Q-SUB has a total of 10 sockets in the front grill and side panels to accept the Z5153 Locking pins 8 mm that connect to the array links of the Q1 system. Two runners extend from the rear to the front panel of the cabinet protecting the bottom panel against scratching. Two correspondingly shaped recesses are incorporated in the top panel of each cabinet that accept these runners to prevent cabinet movement when stacking Q-SUBs.

**NOTICE:** Only operate Q-SUB loudspeakers with a correctly configured d&b amplifier, otherwise there is a risk of damaging the loudspeaker components.

### Connections

The Q-SUB cabinet is fitted with a pair of EP5 connectors. All five pins of both connectors are wired in parallel. The Q-SUB uses the pin assignments 3/4 and 5. Pin 5 is used for SenseDrive (only available when using a D12 amplifier and 5-wire cabling). Pins 1/2 are designated to Q-Series full range systems. Using the male connector as the input, the female connector allows for direct connection to additional loudspeakers.

The Q-SUB can be supplied with NL4 output connectors as an option. The D12 SenseDrive function is not available when using NL4 connectors. Pin equivalents of EP5 and NL4 connectors are listed in the table below.

| EP5 | 1  | 2  | 3  | 4  | 5 (SenseDrive) |
|-----|----|----|----|----|----------------|
| NL4 | 1+ | 1- | 2+ | 2- | n.a.           |

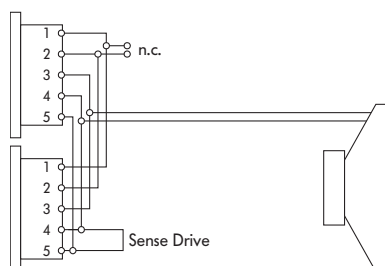

**Fig. 2: Connector wiring**

## Operation with D6 or D12

Select the controller setup Q-SUB.

Within the D12 amplifier this is available in "Dual Channel" and "Mix TOP/SUB" mode.

Selecting Q-SUB mode in the D6 or D12 enables up to two Q-SUB cabinets to be driven by the respective channel.

Selecting the Q-SUB configuration along with the CSA mode enables up to two Q-SUB cabinets to be driven by the respective channel.

In applications with low continuous levels and low ambient temperatures up to three cabinets can be connected to a D12 channel.

### Controller settings

#### 100 Hz circuit

If the 100 Hz circuit is selected, the upper operating frequency of the system is reduced from 130 Hz to 100 Hz.

#### CSA

CSA (Cardioid Subwoofer Array) is a method to combine three or multiples of three subwoofer cabinets to form an array with exceptional directivity at low frequencies.

A Q-SUB cabinet driven in CSA mode eliminates the energy radiated to the rear of the two front radiating Q-SUB cabinets (CSA not selected).

CSA decreases the low end diffuse sound field, significantly improving the direct-to-diffuse energy ratio in the audience areas.

Please note that all other settings of the amplifiers driving a CSA have to be identical (input signal, level, 100 Hz, EQ, delay).

Please refer to d&b TI 330 (d&b code D5330.E), which describes the setup in detail. The TI can be downloaded from the d&b website at [www.dbaudio.com](http://www.dbaudio.com).

## Operation with E-PAC

Selecting Q-SUB mode enables the E-PAC to drive one Q-SUB loudspeaker.

The 100 Hz setting is available. The characteristics of the 100 Hz setting are explained in the previous section "Operation with D6 or D12 - Controller settings".

**Note:** Please note that the E-PAC does not support the Cardioid Subwoofer Array configuration (CSA).

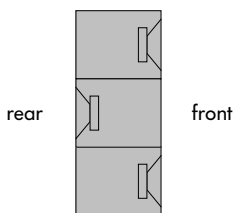

**Fig. 3: CSA Stack (Example)**

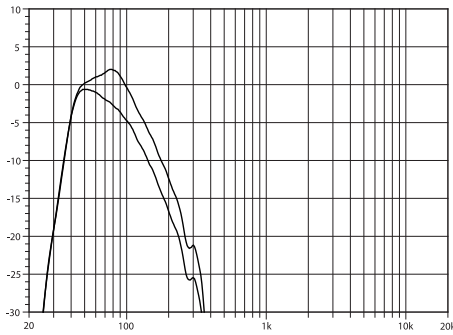

**Fig. 4: Q-SUB frequency response, standard and 100 Hz settings**

## Technical specifications

### Q-SUB system data

|   |                  |
|---|------------------|
| Frequency response (-5 dB standard).....                            | 40 Hz ... 130 Hz |
| Frequency response (-5 dB 100 Hz mode).....                         | 40 Hz ... 100 Hz |
| Max. sound pressure (single cabinet, 1 m, free field) with D12..... | 133 dB           |
| Max. sound pressure (single cabinet, 1 m, free field) with D6.....  | 129 dB           |
| (SPLmax peak, pink noise test signal with crest factor of 4)        |                  |
| Input level (100 dB-SPL/1 m).....                                   | -13 dBu          |

### Q-SUB subwoofer

|   |                            |
|---|----------------------------|
| Nominal impedance.....                          | 8 ohms                     |
| Power handling capacity (RMS / peak 10 ms)..... | 400/1600 W                 |
| Components.....                                 | 18" driver                 |
| Connections.....                                | 2 x EP5                    |
| .....optional 2 x NL4                           |                            |
| Pin assignments.....                            | EP5: 3/4, SenseDrive pin 5 |
| .....NL4: 2+/2-                                 |                            |
| Weight.....                                     | 42 kg (92.6 lb)            |

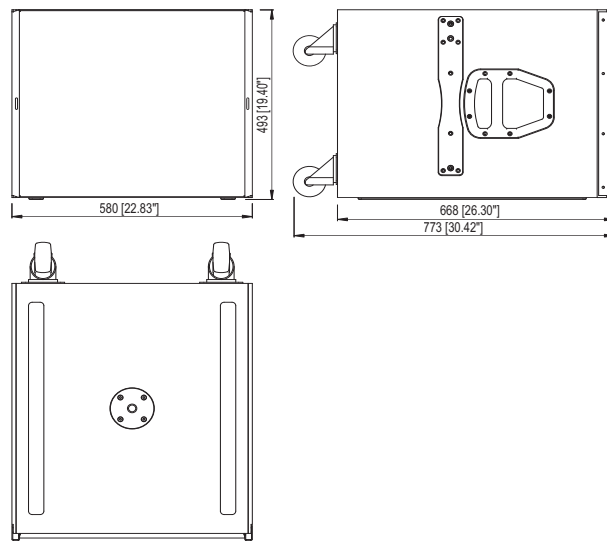

**Fig. 5: Q-SUB cabinet dimensions in mm [inch]**

### Q-SUB and Q1 cabinets

**NOTICE:** When Q-SUBs are used together with Q1 cabinets in a flown array, the Q-SUB cabinets **MUST** be positioned at the top of the column.

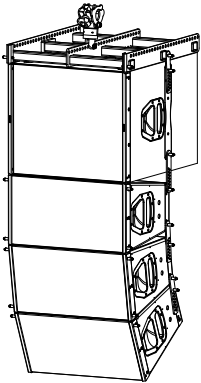

Fig. 6: Q1/Q-SUB Line Array

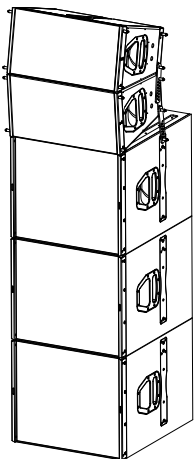

Fig. 7: Q1/Q-SUB Stack

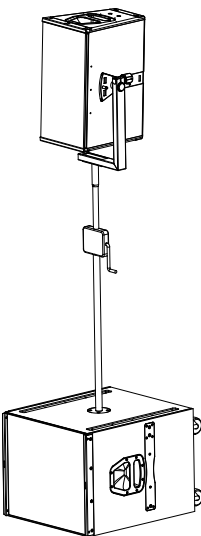

Fig. 8: Q-SUB with Z5013 Loudspeaker stand M20 with winder and Q7

Q1 and Q-SUB cabinets use the same sockets in the front grill and side panels to accept the Z5153 Locking pin 8 mm.

Located on the top of the side panels of the Q-SUB cabinet is an additional socket that enables the Q1 cabinet to be tilted downwards up to 6° for ground stacked use. In this case, the Z5152 Q Front links have to be rotated through 180° before attachment to allow the Q1 cabinet to be tilted to the front (see picture below).

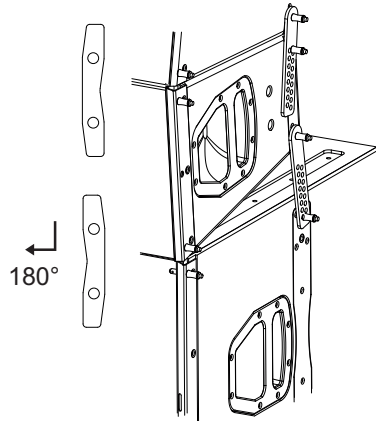

Fig. 9: Orientation of Z5152 Q Front links

### Q-SUB and Q7 cabinets

An M20 threaded flange in the top panel accepts the Z5013 Loudspeaker stand M20 with winder for the deployment of full range cabinets such as Q7 together with the Z5150 Q Swivel bracket and the Z5024 High stand adapter.

## Manufacturer's declarations



### EU conformity of loudspeakers (CE symbol)

This declaration applies to

**- Q-SUB      Z0510**

manufactured by d&b audiotechnik GmbH.

All production versions of this type are included, provided they correspond to the original technical version and have not been subject to any later design or electromechanical modifications.

We herewith declare that said products are in conformity with the provisions of the respective EC directives including all applicable amendments.

A detailed declaration is available on request and can be ordered from d&b or downloaded from the d&b website at [www.dbaudio.com](http://www.dbaudio.com).

### WEEE Declaration (Disposal)

Electrical and electronic equipment must be disposed of separately from normal waste at the end of its operational lifetime.

Please dispose of this product according to the respective national regulations or contractual agreements. If there are any further questions concerning the disposal of this product please contact d&b audiotechnik.