

**D12 Amplifier**  
**Software manual (5.2EN)**  
**(Firmware V2.x.x)**

## **General Information**

D12 Amplifier  
Software manual (Firmware V2.x.x)

Version 5.2EN, 02/2008, D2013.E.05

Copyright © 2008 by d&b audiotechnik GmbH; all rights reserved.

Keep this manual with the product or in a safe place so that it is available for future reference.

When reselling this product, hand over this manual to the new customer.

If you supply d&b products, please draw the attention of your customers to this manual. Enclose the relevant manuals with the systems. If you require additional manuals for this purpose, you can order them from d&b.

d&b audiotechnik GmbH  
Eugen-Adolff-Strasse 134, D-71522 Backnang, Germany  
Telephone +49-7191-9669-0, Fax +49-7191-95 00 00  
E-mail: docadmin@dbaudio.com, Internet: www.dbaudio.com

# Contents

<b>1. Introduction.....</b>	<b>5</b>
1.1 Block diagram of the D12 DSP software.....	5
<b>2. The D12 operating software.....</b>	<b>6</b>
2.1 D12 menu tree.....	6
2.2 D12 user interface.....	7
Conventions for the cursor and menu control.....	7
2.3 D12 Boot screen.....	8
2.4 D12 Main screen.....	8
D12 Settings menu.....	9
Input.....	9
Output (Output routing).....	9
Channel A (B).....	10
Setup Channel A (B).....	10
Source (Input routing).....	10
Speaker.....	10
Filter_1, Filter_2, Filter_3.....	11
Equalizer.....	12
Set.....	12
PEQ function.....	13
Notch function.....	13
Delay.....	13
Levels.....	14
System Check.....	14
System Check menu.....	15
Load Monitoring.....	16
Load Monitoring menu.....	16
Driver menu.....	16
Calibrate.....	17
Reset of Load Monitoring errors.....	18
Frequency Generator.....	18
Link A»B.....	18
AmpPreset.....	19
Remote.....	20
Lock.....	21
Options.....	22
Device Name.....	23
Display.....	23
Information.....	23
Log.....	24
PS Log.....	24
Channel A (B).....	25
Input Monitoring.....	27
Important notes on Input Monitoring.....	27
Input Monitoring menu.....	28
Power Supply.....	29
Buzzer.....	29
TSM Detection (Top/Sub-Mismatch).....	29
2.5 Display messages.....	30
2.5.1 Error messages.....	30
2.5.2 System Check, Load and Input Monitoring.....	31
2.5.3 Error messages during operation.....	31
2.5.4 Further messages.....	32
2.6 System Reset.....	32

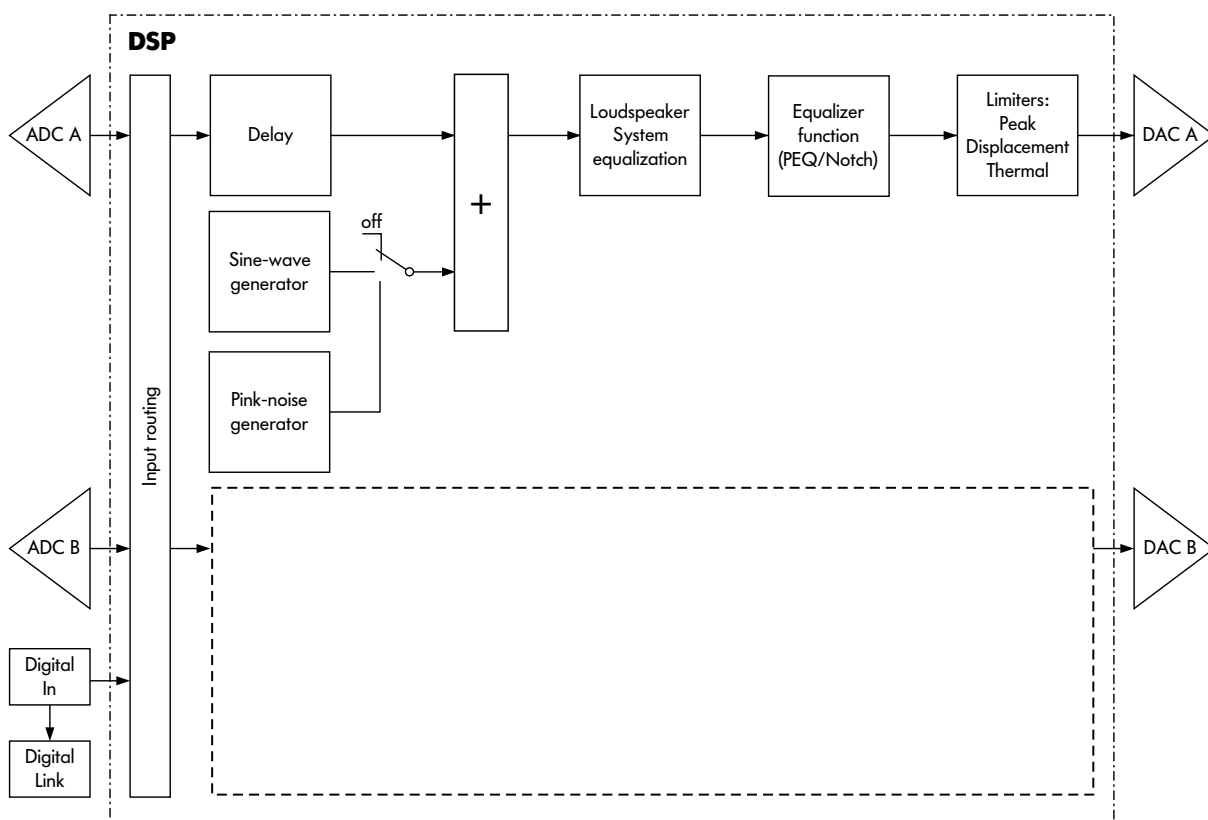
<b>3. D12 Firmware update.....</b>	<b>33</b>
3.1 Firmware Installer.....	33
3.2 D12 Firmware update via D6-D12-dbUpdate.....	33
3.3 D12 Firmware update via CAN-Bus and R10.....	33
<b>4. Remote control &amp; monitoring.....</b>	<b>34</b>
4.1 Remote-Mode "dbCAN" .....	34
4.2 Remote-Mode "RIB" .....	34

# 1. Introduction

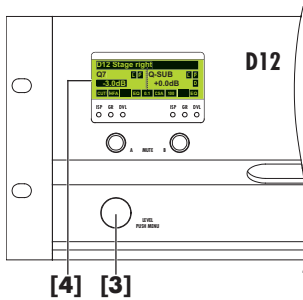
This manual describes the structure, access (user interface) and functions of the firmware of the d&b D12 Amplifier. A detailed description of the D12 hardware and technical specifications is given in the D12 Hardware manual, which is also provided with the D12.

A number of publications with supplementary information on our products are available from the documentation section of our website at [www.dbaudio.com](http://www.dbaudio.com). You can either download these directly or use the online order form to request a printed version. If the document you want is not detailed on the form, please enter the title in the box after entering your address information.

## 1.1 Block diagram of the D12 DSP software







## 2.2 D12 user interface

The LCD [4] acts as a user interface for all menus within the D12. The cursor is controlled via the digital rotary encoder, LEVEL/PUSH MENU [3]. In the main menu the encoder acts as a level control. Pushing or turning the encoder gives access to different menu levels or allows configurations or values to be entered.

Also refer to the D12 Hardware manual, section 3. Controls and indicators.

### Conventions for the cursor and menu control

#### Position-Cursor

Turning the encoder moves the cursor through the menu. Turning to the right moves the cursor down in the menu tree or to the right. Turning to the left moves the cursor up in the menu tree or to the left. Pushing the encoder activates the Edit-Cursor, except for switching functions (e.g. "on/off"). In these instances pushing the encoder leads directly to a change in value or condition (toggle).

#### Edit-Cursor

The current value is displayed beside the cursor and is changed by turning the encoder. Turning to the right increases the value, tuning to the left decreases it. A change is immediately effective, except for the functions "Speaker Selection", "Lock", "Remote", "Device Name" and "Backlight" where a confirmation is required. Exit the edit mode by pushing the encoder and return to the Position-Cursor.

#### Information-Cursor

The Information-Cursor indicates fields within the menu tree where the displayed data cannot be changed.

#### Menu-Change

An arrow indicates another menu level. Selecting it with the Position-Cursor and pushing the encoder enters the corresponding submenu.

#### Back

**Short click:** exits the selected menu by moving back one level.

**Long press** (approx 1 sec.): navigates back to the main menu.

#### Scroll-Bar

Where a menu tree is longer than can be displayed, a Scroll-Bar is shown on the right hand side of the display for orientation.

### Other Cursors or Signs

#### Highlight

A highlighted field indicates that the data displayed can be changed in edit mode (see also Edit-Cursor above).

#### Pointer

In the submenus "Lock/Code" and "Device-Name" the field for text input is highlighted and additionally indicated by an arrow.



Fig. 1: D12 Boot screen

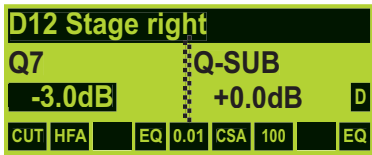


Fig. 2: D12 Main screen

### 2.3 D12 Boot screen

The boot procedure takes approximately 4 seconds during which the device name, the manufacturer's name (d&b audiotechnik) and the firmware version are displayed.

The transition to the Main screen is carried out automatically.

### 2.4 D12 Main screen

The main screen displays all important settings and status information in one view.

In the first line the device name is displayed. If no device name has been entered, the firmware version is displayed.

Depending on the selected output mode there are two different main screens as described in the table below.

Dual channel or Mix Top/Sub mode	2-Way Active mode
<p><b>Fig. 3: D12 Main screen in Dual channel / Mix Top/Sub mode</b></p> <p>Starting from the second line the main menu of the D12 in Dual channel or Mix Top/Sub mode is split into channel A and B and the following settings and information are displayed:</p> <p>Loudspeaker setups (Speaker type) and input gain, status of the delay and Link A»B.</p> <p>The lowest line shows the status or value of the following settings for both channels: Filter_1, Filter_2, Filter_3 (value), EQ. In the center of this status line the dbCAN-Id (if remote mode dbCAN is selected) or the remote mode (if not dbCAN) is displayed. Please refer to the Remote menu section on page 20.</p> <p>Using the encoder (LEVEL/PUSH MENU) the input gain can be adjusted in steps of 0.5 dB (-57.5 dB to +6 dB). A brief press on the encoder changes between level control of channel A and B</p>	<p><b>Fig. 4: D12 Main screen in 2-Way Active mode</b></p> <p>Starting from the second line the main menu of the D12 in 2-Way Active mode is split in two sections and the following settings and information are displayed:</p> <p>Loudspeaker set up and input gain, the selected output mode (Active) the status and value of the delay. If the delay is switched off the initial delay time of 0.3 ms is displayed.</p> <p>Starting from the left the lower line shows the status or value of the following settings: Filter_1, Filter_2, Filter_3 (value), EQ. On the right hand side of this status line the remote mode (if selected) and the dbCAN-Id (if remote mode dbCAN is selected) is displayed. Please refer to the Remote menu section on page 20.</p> <p>Using the encoder (LEVEL/PUSH MENU) the input gain can be adjusted in steps of 0.5 dB (-57.5 dB to +6 dB).</p>

Tab. 1: Main screen depending on output modes

If an error occurs (the red OVL/Err-LED flashes), an error message with channel information will alternate with the device name in the top line of the LCD.

In Standby-Mode, the display alternates between the device name and "Standby".

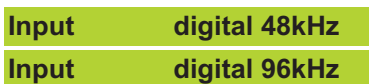
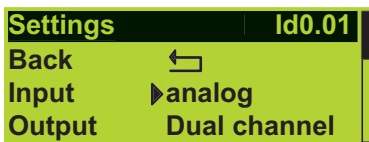
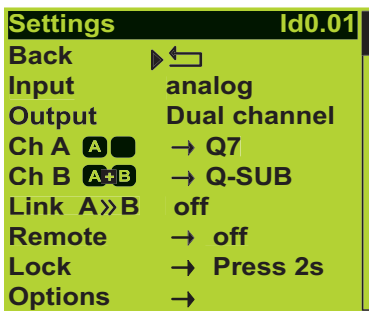
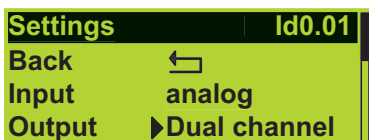
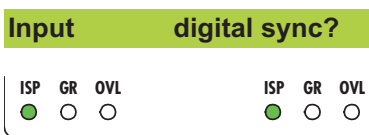


Fig. 5: Supported sampling rates



Fig. 6: Non supported sampling rate e.g. 44.1 kHz



## D12 Settings menu

From the main screen the "Settings menu" is entered by pressing the encoder for approx. 1 sec. It contains general settings for the device and gives further access to submenus.

In the first line the dbCAN-ID is displayed on the right hand side. A detailed description of the CAN-ID is given in the submenu "Remote" and the Remote section on page 20 in this manual.

**Back**

Exits the submenu.

## Input

Selecting "Input" and pushing the encoder allows the setting of the input type. Turning the encoder one detent to the right and back toggles between analog and digital input.

### analog:

The analog input section INPUT A/B and INPUT LINK A/B is active.

### digital:

The digital AES/EBU INPUT and LINK is active.

### Notes on the digital AES/EBU input ⇒ Sampling rates:

The input accepts signals with sampling rates of 48 or 96 kHz. The frequency is detected automatically and will be displayed as shown opposite.

Signals with other common sampling rates (32/44.1/88.2 kHz) are detected but cannot be used by the D12. They will be indicated with a question mark (?) as shown opposite.

The digital inputs are supervised for correct synchronization with the input signal. Short term interruptions or loss of quality are indicated by flashing ISP-LEDs together with the message "sync?" instead of the detected sampling rate.

If no sampling rate is displayed there is either no input signal or a signal with unusable quality or an unknown (non standard) sampling rate.

## Output (Output routing)

Selecting "Output" and pushing the encoder allows the setting of the following output configurations

1. Dual channel
2. Mix Top/Sub
3. 2-Way Active

Depending on the selection the corresponding pin assignment of the loudspeaker output connectors will be set automatically.

**Notes:** After a change of the output configuration the D12 outputs are muted. Use the respective MUTE A or MUTE B switches to unmute it.

A detailed description of the D12 output configurations is given in the D12 Hardware manual, which is also supplied with the D12 Amplifier.

Input	analog
Output	Dual channel
Ch A	A → Q7
Ch B	A+B → Q-SUB

Setup Channel A	
Back	←
Source	Input A
Speaker	Q7

Source	▶ Input A+B
--------	-------------

Ch A	A → Q7
Ch B	A+B → Q-SUB

Speaker	▶ → Q7
---------	--------

Speaker Selection A		
▶ Q7	V1.01	
Ok?	+Clear?	Cancel

---

## Channel A (B)

---

For both Channel A and B the functions and submenus (menu structure) are similar. Therefore "Channel B" is stated in brackets (B).

Selecting "Channel A (B)" and pushing the encoder enters the submenu "Setup Channel A (B)".

---

## Setup Channel A (B)

---

### Source (Input routing)

Within the submenus "Channel A" and "Channel B" the input source for the respective channel can be selected.

Selecting "Source" and pushing the encoder allows the setting of the following routings:

- Input A:** The respective channel is fed from input A.
- Input B:** The respective channel is fed from input B.
- Input A+B:** The respective channel is fed from input A+B.  
(Input A+B are summed with a 6 dB attenuation)

The status of the selected input source is displayed in the settings menu as shown in the graphics opposite.

### Notes on the digital AES/EBU input ⇒ Input routing:

According to the AES standard (AES3-2003 - Stereophonic mode) the AES channels are assigned to the D12 controller as follows:

- D12 Channel A:** AES left or A channel (subframe 1)
- D12 Channel B:** AES right or B channel (subframe 2)

---

## Speaker

---

### Speaker Selection

Selecting "Speaker" and pushing the encoder enters the submenu "Speaker Selection" which enables the selection of loudspeaker configurations for all current d&b loudspeakers, depending on the selected output mode.

On the right hand side the software version of the selected speaker configuration is displayed.

A change of the loudspeaker type has to be confirmed. This can be done by selecting "Ok" or "+Clear". Both are marked by a flashing question mark (?).

#### Ok

Selecting "Ok" and pushing the encoder confirms the configuration and exits the submenu "Speaker Selection".

#### +Clear

Selecting "+Clear" and pushing the encoder confirms the configuration and exits the submenu "Speaker Selection" and clears the user settings of this channel. The following operations are executed:




- Reset of configuration switches (Filter\_1, Filter\_2, Filter\_3)
- Reset of Delay (the selected unit will be kept)
- Reset of all EQ settings
- Load- and Input Monitoring will be set to "off"
- The respective channel will be muted

#### Cancel (⇒ Back ←)

Exits the submenu "Speaker Selection" while the previous configuration remains active.

<p><b>Dual channel mode:</b></p> <p>In "Dual channel mode" the following d&amp;b loudspeaker setups can be selected for both channels:</p> <ul style="list-style-type: none"> <li>- C-Series (except for C3)</li> <li>- E-Series</li> <li>- Q-Series</li> <li>- B1/B2 subwoofers</li> <li>- Ci-Series</li> <li>- M4 passive</li> <li>- MAX/MAX12 passive</li> <li>- Linear</li> </ul>	<p><b>Mix Top/Sub mode:</b></p> <p>In "Mix Top/Sub mode" the following d&amp;b loudspeaker setups can be selected while TOP cabinets are selected on Channel A and SUB cabinets on Channel B.</p> <p><b>Channel A - TOP cabinets:</b></p> <ul style="list-style-type: none"> <li>- C-Series TOPs (except for C3)</li> <li>- E-Series TOPs</li> <li>- Q-Series TOPs</li> <li>- Ci-Series TOPs</li> <li>- M4 passive</li> <li>- MAX/MAX12 passive</li> <li>- Linear</li> </ul> <p><b>Channel B - SUB cabinets:</b></p> <ul style="list-style-type: none"> <li>- C-Series subwoofers</li> <li>- E-Series subwoofers</li> <li>- Q-Series subwoofers</li> <li>- B1/B2 subwoofers</li> <li>- Ci-Series subwoofers</li> </ul>	<p><b>2-Way Active mode:</b></p> <p>In "2-Way Active mode" the following d&amp;b loudspeaker setups can be selected:</p> <ul style="list-style-type: none"> <li>- J-Series</li> <li>- C3</li> <li>- F1222</li> <li>- M2</li> <li>- M4 active</li> <li>- MAX/MAX12 active</li> </ul>
---	--	---

**Tab. 2: D12 Speaker Selection depending on selected output modes**

<b>Speaker</b>	<b>▶→ Q7</b>	
CUT	on	
HFA	on	
CPL	off	

**Filter\_1, Filter\_2, Filter\_3**

The name of the filter is displayed on the left of the LCD followed by its status or value and a pictogram or graphic representation of the filter's frequency response.

The type of filters available depends on the selected loudspeaker configuration.


The display [---] indicates that the respective filter is not available for the loudspeaker type selected.

**on/off**

The schematic change in response is indicated by the pictogram.

**[Value] (Filter\_3)**

"Filter\_3" can be set to different values. The schematic change in response is indicated by the pictogram.

<b>Filter_1</b>	<b>Filter_2</b>	<b>Filter_3</b>
Configuration of crossover frequencies for TOP/SUB, e.g. CUT, 100 Hz, Infra, +B2	Compensation towards listening distance, e.g. HFA, HFC. CSA (Cardioid Subwoofer Array) 	Array-EQ (compensation of coupling effects) ⇒ CPL Range: -9 dB ... 0 dB Cut (Lo shelf) 0 dB ... +5 dB Boost (65 Hz, Bell)

**Tab. 3: Settings Filter\_1, \_2, \_3**

**Notes:**

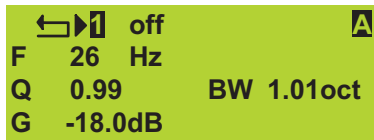
A detailed description of the filters available for each loudspeaker is given in the respective loudspeaker manuals.

A detailed description of the CSA function (Cardioid Subwoofer Array) is given in the technical information TI 330 (d&b code D5330.E).

Equalizer ▶ off Set →

Equalizer ▶ off Set →

Equalizer on Set ▶ →



## Equalizer

A 4-band parametric equalizer providing optional Boost/Cut ("PEQ") or Notch filtering is available for each channel independently in the signal path before the limiting circuit. The EQ function has a Master on/off while each of the four bands can be switched independently. In Dual channel or Mix Top/Sub mode the EQ sections of both channels can be linked using the "Link A»B" function in the "Settings menu".

**Note:** If several EQ bands are set with a high boost in the same frequency range, this **may cause** overflows within the DSP. These errors are recognized internally and the D12 will mute the channel. The error message "DSP Error 16" is displayed. The error can be cleared by changing the filters or by switching off the EQ function.

### on/off

Master switch for the EQ function.

### Set

Selecting "Set" enters the submenu and gives access to the four EQ bands. Turning the encoder to right and pushing the encoder gives access to the individual EQ bands.

### on/off

In the submenu "Set" the master switch for the EQ function is also accessible.

### EQ [number]

Turning and pushing the encoder in at least one of the EQs allows direct access to the individual EQ filters without the necessity to revert to the "Set menu".

### off/PEQ/Notch

Pushing the encoder enables selection of either the "off", "PEQ" (Parametric Equalizer) or "Notch" function.

The status of the respective EQ band is indicated as follows:

- The respective EQ Band is switched "off" (flat)
- P** The respective EQ Band is switched to "PEQ" function
- N** The respective EQ Band is switched "Notch" function

The resulting overall frequency response of all (active) filters is shown at the bottom of the display.

▶ ← 1 PEQ A  
 F 26 Hz  
 Q 0.99 BW 1.01oct  
 G -18.0dB

▶ ← 3 Notch A  
 F 3460 Hz  
 Q 25.00 BW 0.04oct  
 G -----

Delay ▶ off 0.3 ms

Delay ▶ on 0.3 ms

Delay on ▶ 10.0 ms

Delay on 3.4 ▶ m

Delay on 8.9 ▶ ft

## PEQ function

---

### Parametric Equalizer (PEQ)

The following parameters can be edited:

#### F

Filter center frequency adjustable from 20 Hz to 20 kHz in 3 % steps.

#### Q

The Q of the filter is adjustable from 0.5 ... 25 in 10 % steps. In addition, the bandwidth (BW) as a result of the Q is displayed as a value (2.0 ... 0.04 octaves) in a non-editable field.

#### G

Gain, adjustable from -18 dB to +6 dB in 0.2 dB steps.

## Notch function

---

The following parameters can be edited:

#### F

Filter center frequency adjustable from 20 Hz to 20 kHz in 3 % steps.

#### Q

The Q of the filter is adjustable from 0.5 ... 25 in 10 % steps. In addition, the bandwidth (BW) as a result of the Q is displayed as a value (2.0 ... 0.04 octaves) in a non-editable field.

#### G

The parameter "Gain" (G) cannot be edited in "Notch" mode. The center frequency is fully attenuated ( $\Rightarrow -\infty$  dB).

## Delay

---

A signal delay is available for each channel independently to allow delay settings of up to 340 ms. (100 m/328.1 ft).

### on/off

Switches the delay on/off without affecting the entered delay value.

### [Value]

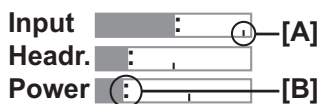
Delay time adjustable from 0.3 to 340 ms in steps of 0.1 ms or a corresponding value depending on the unit selected.

### [Unit]

Enables selection of the delay unit in either milliseconds [ms]; meters [m]; or feet [ft].

## Levels ▶ →

Fig. 7: D12 Levels



## Levels

Selecting "Levels" and pushing the encoder enters the submenu.

Turning the encoder one detent to the right and back toggles between channel A and B.

Pushing the encoder exits the submenu.

In the "Levels screen" the following values are displayed as bar graphs and/or as numeric values:

### Input gain/Temperature of the device

In the first line the input gain setting of the respective channel is displayed as the numeric value in dB and the temperature of either the amplifier or the power supply (whichever value is higher).

### Input

Input signal level as bar graph and the numeric value is displayed in dBu. The small vertical mark [A] represents the threshold of input level where an input overload occurs (red OVL LED). The colon [B] acts as a peak hold for 1 s.

### Headr. (Headroom)

The bar graph shows the relationship between modulation and gain reduction (GR). The small vertical mark [A] indicates the gain reduction threshold (0 dB headroom), the colon [B] acts as a peak hold for 1 s. The gain reduction (GR) LED (yellow) indicates a gain reduction of more than 3 dB.

### Impedance Z

The impedance of the loudspeaker(s) presented to the output of the D12, displayed only as a numeric value in ohms. The value is measured with the actual output signal and may therefore vary with its spectral content. The measurement range reaches from 0 ohms (short circuit) to 255 ohms (open loop,  $I = 0$ ,  $Z \Rightarrow \infty$ ). When the signal is too low the maximum of 255 ohms is displayed.

### Power

The actual output power, displayed as bar graph and as a numeric value in watts, the colon [B] acts as a peak hold for 1 s.

## System Check

System Check is a powerful and convenient tool to check the condition of either a single d&b loudspeaker or a complete d&b sound system driven by the D12. It is preferably used in conjunction with the d&b Remote network and the ROPE C software (from version 1.1.3).

System Check uses the amplifier's capability to measure the impedance connected to its outputs using a sine wave signal created by the DSP section of its controller.

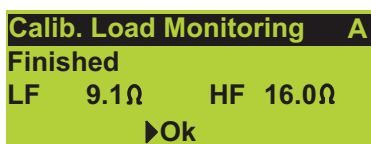
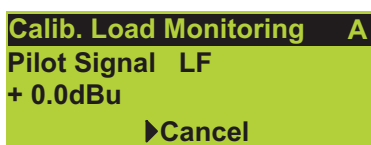
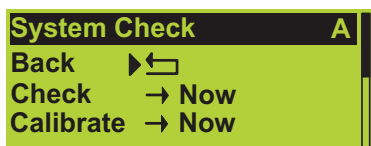
System Check is related to the Load Monitoring feature of the D12. Both functions share the same measuring principle and impedance reference values. While System Check uses a single measuring run Load Monitoring supervises continuously by recurring measurements. System Check creates a detailed report about the connected loads whereas Load Monitoring is confined to an error message if a fault is detected.

**Note:** This section describes the System Check menus in the D12. A more detailed description of System Check and its application is given in the technical information TI 360 (d&b code D5360.E.).

## System Check ▶ →

Selecting "System Check" and pushing the encoder enters the submenu.

## System Check menu



### Check

**Note:** Before running the procedure, ensure the system has been calibrated and the respective channel is not muted.

Selecting "Check Now" directly starts the measurement while the progress of the procedure is displayed. It can be canceled/interrupted and restarted at any time by pushing the encoder during the procedure.

A System Check can be executed while the system is transmitting program, at high level, however, the accuracy of the measurement will decrease.

After a successful check run "Ok" appears.

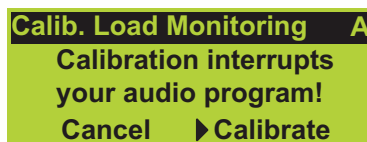
Confirm to get back to the System Check menu.

If the check procedure was not successful, a respective error message will be given out.

Also refer to section 2.5.2 on page .

### Calibrate

Selecting "Calibrate Now" enters the submenu "Calib. Load Monitoring" and the following message is given as a precautionary measure:



Selecting "Calibrate" starts the calibration procedure while the progress of the procedure is displayed. It can be canceled/interrupted and restarted at any time by pushing the encoder during the procedure.

After a successful calibration the reference value are displayed and "Ok" appears in the bottom line of the calibration screen.

Confirm to get back to the System Check menu.

If the calibration was not successful (e.g. no load connected), a respective error message will be given out.

Also refer to section 2.5.1 Error messages on page 30.

### Last Check/Calibration

Further down in the System Check menu a report about the connected loads is given for both the LF, MF and HF section.

**Chk:** The current values derived from the last check are displayed.

**Cal:** The reference values derived from the last calibration are displayed.

---

## Load Monitoring

---

### Features

d&b Load Monitoring is designed to identify a possible loudspeaker malfunction. It is especially designed to fulfill the requirements of the European Standard EN 60849 "Elektroakustische Notfallwarnsysteme" (equivalent to international standard IEC 60849 "Sound Systems for Emergency Purposes").

### Function

A Calibration process carried out with the completely set up system determines the impedance for each channel and calculates the related upper and lower impedance limits.

While the system is operating d&b Load Monitoring continuously checks the load impedance separately for both frequencies detecting any changes in loudspeaker impedance and reporting an error if the limits are exceeded. To do so, Load Monitoring uses inaudible Pilot Signals, which are faded in for approximately 2 seconds in user defined intervals.

**Notes:** The resolution of Load Monitoring regarding failures of single components depends on the type and the number of loudspeakers connected to each channel. A detailed description is given in the technical information TI 360 (d&b code D5360.E.).

Load Monitoring does not work if:

- the amplifier is switched off or to standby mode
- the respective channel is muted.
- the pilot signal level is too low.

Selecting "Load Monitoring" and pushing the encoder enters the submenu.

Load Monitoring ▶ → off

Load Monitoring A  
Back ←  
Mode ▶ off  
Detection Time 99s

D12 Stage right  
Q7 L Q-SUB L  
-3.0dB +0.0dB D  
CUT HFA EQ 0.01 CSA 100 EQ

LF Driver ▶→  
HF Driver →  
Calibrate → Now

---

## Load Monitoring menu

---

### Mode

Selecting "Mode" within the "Load Monitoring menu" and pushing the encoder (Mode on – indicated as "■" in the main menu) activates "Load Monitoring".

### Detection Time

The maximum time in which a loudspeaker malfunction will be detected by the system. The interval of the pilot signals is derived from this parameter.

---

## Driver menu

---

The LF Driver menu serves as an example. The same menu is also available for the HF and/or MF Driver.

**Note:** All settings (except for "Last-Err") are determined during the Calibration process. Only experienced users should edit the following settings.

LF Driver		A
Back		▶ ←
Z Min	- 20%	
Z Max	+30%	
Cal	0.0 Ω	
Last Mon	0.0 Ω	
Chk	0.0 Ω	
Last Error	0.0 Ω	
Pilot Freq	10Hz	
Pilot Level	-24.5dBu	
Threshold	15V	

### Definition of values:

#### Min

Lower limit of the impedance window which is set to -20 % by default.

#### Max

Upper limit of the impedance window which is set to +30 % by default.

#### Calibration

The impedance reference values derived from the calibration.

#### Last Mon

Impedances detected during the last measurement.

#### Last Check

Impedances detected during the last System Check (see also section System Check on page 14).

#### Last Error

Last impedance values determined that led to an impedance error.

These values are kept even after acknowledgment of the error message. They are only overwritten when another error occurs. A calibration resets them to 0.

#### Pilot Freq.

Test frequency of the pilot signal for the respective driver.

#### Pilot Level

Reference level of the pilot signal derived from the calibration procedure.

#### Threshold

Large signal threshold. If the output signal exceeds this voltage level during the measurement, the tolerance limits for this particular measurement are increased in order to compensate for the reduced accuracy.

### Calibrate

**NOTICE:** Ensure that all components of the system are wired and working correctly before executing the calibration!

Selecting "Calibrate Now" enters the submenu "Calib. Load Monitoring" and the following message will be given as a precautionary measure:

**Calib. Load Monitoring A**  
**Calibration interrupts**  
**your audio program!**  
**Cancel ▶ Calibrate**

**Calib. Load Monitoring A**  
**Pilot Signal LF**  
**+ 0.0dBu**  
**▶Cancel**

**Calib. Load Monitoring A**  
**Finished**  
**LF 9.1 Ω HF 16.0 Ω**  
**▶Ok**

Selecting "Calibrate" starts the calibration procedure while the progress of the procedure is displayed. It can be canceled/interrupted and restarted at any time by pushing the encoder during the procedure.

After a successful calibration the reference values are displayed and "Ok" appears in the bottom line of the calibration screen.

Confirm to get back to the Load Monitoring menu.

If the calibration was not successful a respective error message will be displayed. Also refer to section 2.5.2 on page .

Freq. Generator ▶ → off

Frequency Generator A  
Back ▶◀ Mode off  
Level -42.0dBu  
Frequency 1000Hz

Frequency Generators  
are used by  
Load Monitoring  
▶Ok

D12 Stage right  
Q7 Q-SUB  
-3.0dB +0.0dB D  
CUT HFA EQ 0.01 CSA 100 EQ

Link A»B ▶ off

D12 Stage right  
Q7 ▶Q-SUB  
-3.0dB ▶ +0.0dB  
CUT HFA EQ 0.01 CSA 100 EQ

## Reset of Load Monitoring errors

To reset error indications either:

- Power Off/On on the device or remotely.
- Switch the Load Monitoring Off/On on the device or remotely.

## Frequency Generator

Each amplifier channel is equipped with an independent signal generator offering pink noise or a sine wave signal.

The generator can be used to check the connected loudspeakers or to identify room resonances, for example. The generator is inserted in the signal path after the delay and before the loudspeaker equalization. The test tone will sum with any input signal present.

**Notes:** As a precautionary measure the frequency generator will always be off (Mode = off) after the D12 is powered on.

The frequency generator provides the Pilot Signals for the "Load Monitoring" function. When using "Load Monitoring" the frequency generator function is not available and a message is given as shown in the graphic opposite.

### Mode

Selecting "Mode" and pushing the encoder allows the following settings:

**off:** generator off.

**Sine:** sine wave generator (indicated as "🎵" on the main screen).

**Pink:** pink noise generator (indicated as "🔊" on the main screen).

### Level

Level of the frequency generator in dBu covering a 63.5 dB range from -57.5 dB to +6 dB in 0.5 dB steps. The level value corresponds to the level at the controller signal input. The actual output voltage depends on the channel input gain, the frequency dependent gain of the selected loudspeaker configuration and EQ settings if used.

### Frequency

Frequency adjustable in the range of 10 Hz to 20 kHz in 1 Hz steps.

## Link A»B

In "Dual channel" and "Mix Top/Sub" mode EQ and/or Delay settings of both channels can be linked using the "Link A»B" function. These functions are then controlled in the Channel A menu, in the Channel B menu the linked functions cannot be edited.

On the "Main screen" the "Link A»B" function is indicated by altering the center line to arrows as shown in the graphic opposite.

Selecting "Link A»B" and pushing the encoder allows the setting of the following modes:

**off:** Both controller channels are operated independently.

**EQ:** The EQ function of controller Channel B is linked to controller Channel A.

**Delay:** The Delay function of controller Channel B is linked to controller Channel A.

**EQ+Delay:** Both the EQ and Delay function of controller Channel B are linked to controller Channel A.

**Notes:** In "2-Way Active mode" the "Link A»B" is used permanently to link the channels and cannot be modified. In this mode also the "MUTE A" and the "MUTE B" switches are linked. Therefore the device can be muted/unmuted by either the "MUTE A" or the "MUTE B" switch. After leaving "2-Way Active mode" the "Link A»B" will be set to "off".

## AmpPreset

D12 amplifiers from firmware version V2.12 provide AmpPresets which contain all important user settings of the entire device such as input, output and channel configurations, EQ and delay settings.

Using the D12 AmpPresets a sound system can be operated in different configurations (e.g. "Conference", "Music" or "Emergency Call") without the need of transmitting all detailed settings of the devices used.

There are three types of AmpPreset memories:

**User:** Nine AmpPresets which can be accessed locally or via the d&b Remote network (R10 Service software from V1.0.6). These AmpPresets are used to set the complete D12 to a previously defined configuration for a particular application and can be named individually.

**Alarm:** Three AmpPresets which can only be accessed via the d&b Remote network (R10 Service software from V1.0.6). Intended for use in alarm systems to protect the system settings against local modifications.

**Backup:** Three AmpPresets which can only be accessed via the d&b Remote network (R10 Service software from V1.0.6). Intended for temporary use to back up the current system settings when another AmpPreset is loaded.

Selecting "AmpPreset" and pushing the encoder enters the submenu.

The D12 menu item AmpPreset indicates the last AmpPreset number loaded and is marked by a "1\*" if any setting has been modified since loading. The menu below provides the functions Select, Load, Save, Clear and a name field to manage the AmpPresets.

```
AmpPreset ▶→ 1 *
```

```
AmpPreset      Last 1*
Back ◀         Select▶ 9
Preset Name
Load Save Clear
```

```
AmpPreset      Last 1*
Back ◀         Select 9
MyPreset
Load Save ▶Clear Ok?
```

```
Load Save Clear ▶Ok!
```

```
AmpPreset      Last 1*
Back ◀         Select 9
▶(empty)
---- Save Clear
```

### Select

Turning and pushing the encoder provides access to the nine user preset memories to be loaded, saved or cleared.

To load, save or clear the selected AmpPreset first scroll to the respective menu item (Load, Save or Clear) and press the encoder to select the desired function. "O.k.?" appears (flashing) to confirm the selected function.

### Load

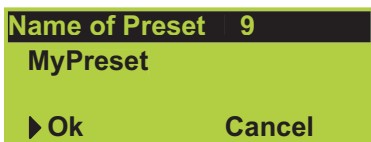
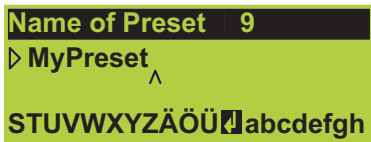
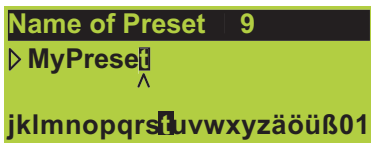
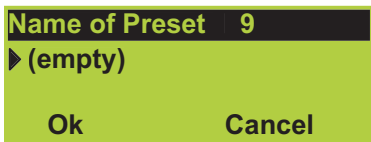
Restore the settings of a stored AmpPreset.

### Save

Store the current amplifier settings in the selected preset memory and name it.

### Clear

The selected AmpPreset memory is cleared and "empty" is displayed.



### Preset Name

Enables the assignment or editing of a Preset Name (maximum 15 characters):

1. Selecting the "Preset Name field" enters the submenu and the cursor is positioned at the beginning of the field.
2. Pressing the encoder enters edit mode. The pointer, (^), indicates the entry position for new or edited characters. A variety of characters (e.g. capital and lower case letters, numbers 0-9 and special characters) is displayed in the bottom line.
3. Each character can be highlighted by turning the encoder. Turning left moves the cursor to the start of the list (A ←), turning right to the end of the list (⇒ @).
4. When you press the encoder, the highlighted letter is entered into the upper line and the pointer advances by one space.
5. Repeat steps 1 to 4 until the complete device name is entered.
6. Exit edit mode by moving the cursor to the return sign (↵) and pressing the encoder.

**Notes:** An existing entry can be completed using the return sign at any position. Succeeding letters are deleted automatically.

Single characters can be kept by simply pressing the encoder and the pointer advances by one space after each entry.

The editing position can be scrolled through the characters by pushing and turning the encoder simultaneously.

### Ok

Selecting "Ok" and pressing the encoder confirms the new setting and exits the submenu.

### Cancel (⇒ Back ↶)

Exits the submenu leaving the previous name installed.

### Remote

#### Mode

Selecting "Mode" the following modes for remote control are available:

- off:** no remote control.
- RIB/TI212:** remote control according to TI212 (Basic remote and RIB Remote. (indicated as "RIB" in the main screen)

**Note:** Selecting the "RIB/TI212" mode (Basic remote) switches the D12 into standby mode. The D12 now can be switched on by applying a permanent DC voltage of 18 to 28 V to pin 7 (+) and 8 (-) of one of the remote connectors (RJ 45). Please refer to section 4. Remote control & monitoring on page 34.

- RIB:** remote control via d&b RIB/ROPE. (indicated as "RIB" in the main screen)

**Note:** Control via d&b RIB only in conjunction with the d&b ROPE 2.0 or ROPE 3 remote software.

- RIB/RS232:** remote control via RS232 and the SERVICE connector of the D12. (indicated as "RIB" in the main screen)

### Sub net 0 to 7

dbCAN Id	▷0.	01
dbCAN Id	▷7.	01
dbCAN Id	7.▷0	1
dbCAN Id	7.▷6	3

### Device Id 01 to 63

Lock ▶ → Press 2s

Lock	
Back	←
Lock now	▶ →
Mode	Press 2s

D12 Stage right			
J12	Active		🔒
-3.0dB	D	0.3ms	
HFC	LFC	C -5	EQ
			CAN 0.01

Show ▶ Main Screen

Password ▶ →

**dbCAN:** remote control via dbCAN (CAN-Bus)/ROPE C.  
In 2-Way Active mode indicated as "CAN" and the "dbCAN Id" e.g. 7.63 in the main screen.  
In Dual channel or Mix Top/Sub mode indicated with the "dbCAN Id" e.g. 7.63 in the main screen.

### dbCAN Id

Setting the "dbCAN identifiers [n].[nn]". The first digit represents the CAN subnet. Eight subnets can be defined (values 0 to 7). Using the two digit device ID for each subnet 63 devices can be defined (values 01 to 63).

### Lock

Selecting "Lock" and pressing the encoder enters the submenu.

### Lock now

Pressing the encoder switches the device into "Lock" mode according to the mode selected below and exits the submenu "Lock". In 2-Way Active Mode a locked device is indicated by "🔒" in the Main screen.

### Mode

Selecting "Mode" and pressing the encoder toggles between two options to protect the device against unintentional operation.

**Press 2s:** prevents accidental operation by locking the front panel controls.

**Password:** password protection preventing operation by unauthorized persons.

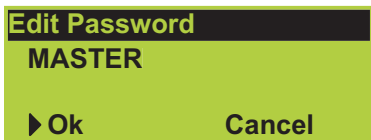
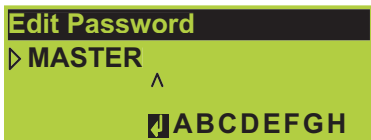
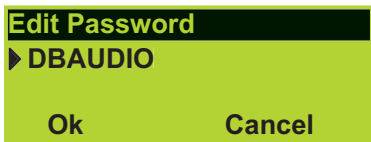
### Show

Selecting "Show" and pressing the encoder allows two different screens to be displayed when the device is locked.

**Main Screen:** switch to the "Main screen".

**Levels Screen:** switch to the "Levels screen".

Selecting "Password" and pressing the encoder enters the submenu "Edit Password".



### Edit Password

Enables the input of a new password or editing of an existing password (maximum 7 characters).

**Note:** | Factory (default) password DBAUDIO.

1. Selecting "Password" enters the "Edit Password" mode and the cursor is positioned at the beginning of the "Password".
2. Pressing the encoder enters edit mode. The pointer (^) indicates the entry position for new or edited characters. The selection of characters (Capital letters) is displayed in the bottom line.
3. Each character can be highlighted by turning the encoder. Turning left moves the cursor to the start of the list (A ⇐), turning right to the end of the list (⇒ Z).
4. When you press the encoder, the highlighted letter is entered into the password line and the pointer advances by one space.
5. Repeat steps 1 to 4 until the complete password is entered.
6. Exit edit mode by moving the cursor to the return sign (↵) and pressing the encoder.

**Notes:** | An existing entry can be completed by the return sign at any position. Succeeding letters are deleted automatically.

Single characters can be kept by simply pressing the encoder and the pointer advances by one space after each entry.

The editing position can be scrolled through the characters by pressing and turning the encoder simultaneously.

### Ok

Selecting "Ok" and pressing the encoder confirms the new setting and exits the submenu "Password".

### Cancel (⇒ Back ⏪)

Exits the submenu leaving the previous password installed.

### Unlocking the device

An attempt to change the status of the device in "Lock" mode is met by the message "Unlock: Press knob 2s" being briefly displayed. Unlock the device as follows:

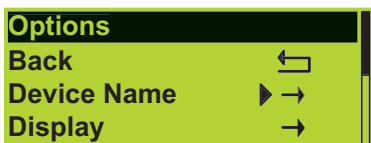
#### Press 2s

Press and hold the encoder for a minimum of 2 seconds until the message "Unlock: Press knob 2s" disappears from the first line of the LCD.

#### Password

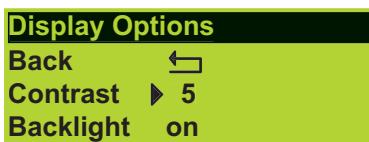
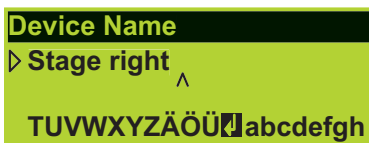
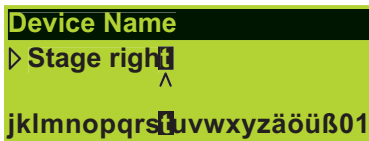
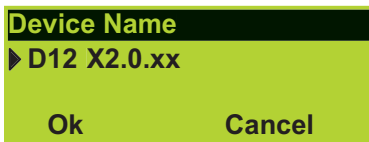
Press and hold the encoder for a minimum of 2 seconds until "Please Enter Password" is displayed. The password is entered as described above under "Password". An incorrectly entered password will revert the device to the screen selected for "Lock" mode.

**Notes:** | If the password has been lost a protected D12 can be released by a System-Reset (See Section 2.6 System Reset on page 32).



### Options

The "Options" menu allows further settings and status retrieval in addition to the operational configurations and parameters of the device.



## Device Name

Enables the assignment or editing of a device name (maximum 15 characters):

1. Selecting "Device Name" enters the submenu and the cursor is positioned at the beginning of the "Device Name". As a factory preset "D12" followed by the firmware version is entered.
2. Pressing the encoder enters edit mode. The pointer, (^), indicates the entry position for new or edited characters. A variety of characters (e.g. capital and lower case letters, numbers 0-9 and special characters) is displayed in the bottom line.
3. By turning the encoder, each character can be highlighted. Turning left moves the cursor to the start of the list (A <=), turning right to the end of the list (=> @).
4. When you press the encoder, the highlighted letter is entered into the upper line and the pointer advances by one space.
5. Repeat steps 1 to 4 until the complete device name is entered.
6. Exit edit mode by moving the cursor to the return sign (↵) and pressing the encoder.

### Notes:

An existing entry can be completed by the return sign at any position. Succeeding letters are deleted automatically.

Single characters can be kept by simply pressing the encoder and the pointer advances by one space after each entry.

The editing position can be scrolled through the characters by pressing and turning the encoder simultaneously.

### Ok

Selecting "Ok" and pressing the encoder confirms the new setting and exits the submenu "Device name".

### Cancel (=> Back <=)

Exits the submenu leaving the previous device name installed.

## Display

Selecting "Display" and pressing the encoder enters the submenu "Display Options".

### Display Options

#### Contrast

Enables adjustment of the display contrast.

#### Backlight

Enables the following settings:

- off:** display illumination permanently off.
- On:** display illumination permanently on.
- timeout 10s:** display is illuminated when the encoder or a MUTE switch is pressed and switches off 10 seconds after the last operation.

### Note:

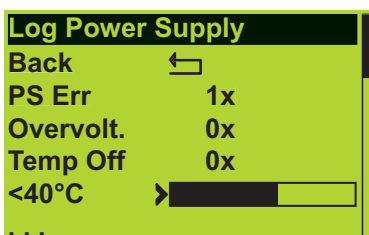
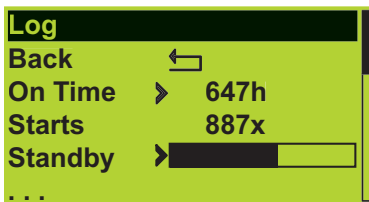
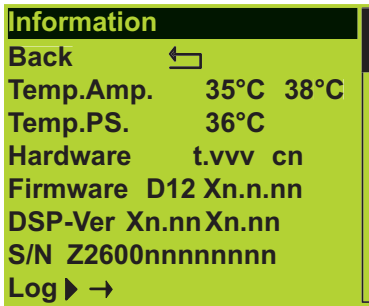
In "Standby mode" the display illumination reverts to "timeout 10s".

## Information

Selecting "Information" and pushing the encoder enters the submenu.

### Temp. Amp.

The temperature of the D12 heat sink.



### Temp. PS

The temperature of the D12 Power Supply.

### Hardware

Hardware type and variant [t.vvv] and identification [cn].

### Firmware

The software version installed in the D12.

### DSP-Ver

The version of active software installed in the D12 DSPs.

### S/N

Serial number of the device.

---

## Log

---

Selecting "Log" and pressing the encoder enters the submenu.

The log book contains information relating to the use and environmental conditions experienced throughout the operating life of the D12.

The bar graphs indicate the time the D12 has been in a certain condition in relation to the total time the device has been connected to a mains power supply and switched on.

For example, a half filled "Standby bar graph" indicates that the D12 has been in "Standby mode" for half of its operating life.

The following information will be recorded:

### On time

Hours counter. Indicating the amount of time the D12 has been connected to a mains power supply and switched on.

### Starts

How often the device has been switched on.

### Standby

Proportion of the "On Time" the D12 has been in Standby mode.

### SysErr

A numerical value indicating the number of times the D12 has entered the error condition "SysErr".

### RemoteErr

A numerical value indicating the number of times the D12 has entered the error condition "RemoteErr".

### DSP Halt

A numerical value indicating the number of times the D12 has entered the error condition "DSP Halt" due to an internal fault.

---

## PS Log

---

Selecting "PS Log" and pressing the encoder enters the submenu.

### PS Err

A numerical value indicating the number of times the D12 has entered the error condition "PS Err".

### Overvolt.

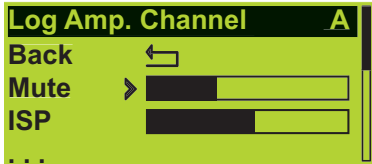
A numerical value indicating the number of times the D12 has entered the error condition "Overvoltage".

### Temp Off

A numerical value indicating the number of times the D12 has switched off with the error condition "Overtemperature" due to overheating.

Channel A ▶→

Channel B ▶→



### Temp. (Temperature Log)

Proportionate temperature ranges.

They display the proportion of "On Time" the D12 has been operated within the temperature ranges listed.

### Channel A (B)

---

Selecting "Channel A (B)" and pressing the encoder enters the submenu.

#### Mute

Proportion of the "On Time" the D12 was muted.

#### ISP

Proportion of the "On Time" an input signal was present at the D12.

#### GainRed

Proportion of the "On Time" the D12 has been operated with gain reduction.

#### Overload

Proportion of the "On Time" the D12 has been operated with too high input level or output current.

**Amp Prot**

A numerical value indicating the number of times the D12 has entered the error condition "Amp Protect", possibly due to a current overload caused by a low impedance or short circuit connected to the output.

**Amp Err**

A numerical value indicating the number of times the D12 has entered the error condition "Amp Error" due to an internal fault.

**Temp Off**

A numerical value indicating the number of times the D12 has switched off with the error condition "Overtemperature" due to overheating.

**ImpErrLf**

A numerical value indicating the number of times the D12 has entered the error condition "ImpErrLf" due to a Load Monitoring fault.

**ImpErrHf**

A numerical value indicating the number of times the D12 has entered the error condition "ImpErrHf" due to a Load Monitoring fault.

**InpMonErr**

A numerical value indicating the number of times the D12 has entered the error condition "InpMonErr" due to an Input Monitoring fault, possibly caused by a missing external pilot signal.

**T/S Mis.**

A numerical value indicating the number of times the D12 has entered the error condition "T/S Mis." due to a TOP/SUB mismatch at the output connectors of the D12 in Dual Channel mode as long as the "TSM Detection" function was not set to off.

**DSP Halt**

A numerical value indicating the number of times the D12 has entered the error condition "DSP Halt" due to an internal fault.

**Temp. (Temperature Log)**

Proportionate temperature ranges.

They display the proportion of "On Time" the D12 has been operated within the temperature ranges listed.

## Input Monitoring

According to the European Standard EN 60849 "Elektroakustische Notfallwarnsysteme" (equivalent to international standard IEC 60849 "Sound Systems for Emergency Purposes") the complete signal chain needs to be monitored. Therefore the "d&b Input Monitoring" functionality allows the detection of an incoming pilot signal to be inserted into the signal chain in front.

### Important notes on Input Monitoring

Input Monitoring can supervise the D12 analog or digital inputs. It is not linked to the channel input routing, therefore it is possible to monitor an input connector while it is not routed to an amplifier channel.

Depending on the selected input mode of the D12 the following Input Monitoring modes are functional:

D12 Input mode	Analog Pilot	Digital Pilot	Digital Lock
analog	Yes	No	No
digital	Yes	Yes	Yes

**Tab. 4: Input Monitoring modes depending on D12 Input mode**

The submenus "Input A" and "Input B" within the "Input Monitoring" menu are related to the D12's input connectors according to the following conventions:

#### D12 input mode is set to "analog"

The analog input connectors INPUT A/B of the D12 can be monitored for incoming pilot signals.

When setting the D12 to input mode analog it is not possible to monitor the digital input or whether the digital input has locked to the incoming digital audio signal (as indicated in the table above - Tab. 4). In this case an error message "A/B: Input monitoring Fault" is given out on the LCD.

#### D12 input mode is set to "digital"

In this case "Input A/B" in the "Input Monitoring" menu are related to the AES channel. The analog input connectors INPUT A/B or the DIGITAL AES/EBU input connector of the D12 can be monitored for incoming pilot signals or whether the digital input has locked to the incoming digital audio signal (Clock).

Example:

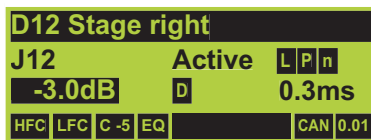
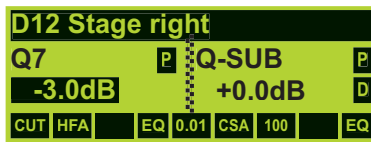
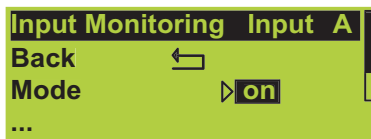
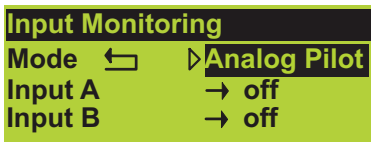
The D12 input mode is set to digital while the analog input connectors are monitored for incoming pilot signals (Analog Pilot). The program signal is fed to the digital input while for emergency calls the D12 will be switched (routed) to the analog inputs of the D12 and the program fed to the digital input will be interrupted.

#### MUTE A/B

**Note:** As the MUTE A/B switches isolate the D12 digital controller from the power amplifiers the MUTE A/B switches do not affect the input connectors of the D12 and therefore "Input Monitoring" remains working (also refer to the D12 Hardware manual in section "Controls and indicators – MUTE A/B").

Input Monitoring ► → off

Selecting "Input Monitoring" and pressing the encoder enters the submenu.



## Input Monitoring menu

### Mode

Selecting "Mode" and pressing the encoder allows the setting of the following functions:

**Analog Pilot:** monitor incoming pilot signal at the analog inputs

**Digital Pilot:** monitor incoming pilot signal at the digital input

**Digital Lock:** monitor whether the digital input has locked

### Input A / Input B

Selecting either "Input A" or "Input B" and pressing the encoder allows the following settings for each channel independently.

### Mode

Selecting "Mode" in the "Input A or B" submenu and pressing the encoder activates "Input Monitoring" (indicated as "P" in the main screen). An error message will be generated if no signal is detected.

### Detection Time

The maximum time interval an interruption of the monitored pilot signal or digital clock is accepted without generating an error message.

### Notch on/off

A notch filter is available to remove the pilot signal from the program signal. However, if activated, the Notch filter remains active even the Input Monitoring is set to off (Mode off). The on/off status of the Notch filter is indicated by "P" in the main screen as shown in the graphic opposite - .

### Frequency

Center frequency of the notch filter adjustable from 1 Hz to 20 kHz in 1 Hz steps.

### Freq. Fine

Fine tuning of the center frequency  $\pm 1$  Hz, 1/100 Hz steps.

### Quality

The Q of the filter is adjustable from 4 ... 42 in 1 detent steps. The center frequency is fully attenuated ( $\Rightarrow -\infty$  dB).

### Detected? no (yes)

The signal level in dBu detected at the set pilot frequency is displayed on the right hand side. "Detected?" is followed by the message ("yes" or "no") depending on the threshold level (see "Threshold" below).

### Threshold

Detection threshold for an external Pilot Signal of the set frequency, adjustable in a range of -122 dBu to +21 dBu in 1 dB steps.

Power Supply ▶ →

Power Supply  
Back ▶ ←  
Mains 230V  
Frequency 50Hz

Buzzer ▶ off

TSM Detection ▶ on

## Power Supply

---

Selecting "Power Supply" and pushing the encoder enters the submenu.

### Mains

The currently measured mains voltage to which the device is connected in volts. The typical accuracy is 2 %.

### Frequency

The detected mains frequency.

## Buzzer

---

An additional acoustical signal for error messages.

### on/off

Turning the buzzer on or off.

## TSM Detection (Top/Sub-Mismatch)

---

**NOTICE** | The "TSM Detection" is set to "on" by factory default. If it is changed to "off" this setting is kept also after the D12 has been powered off.

In "Dual channel mode" all four pins (TOP and SUB pins) of the output connectors are driven. This could cause damage to TOPs when a SUB configuration is selected on the respective channel.

The D12 monitors the current through the different output pins and detects if a wrong cabinet type is connected.

The error message "Top/Sub-Mismatch" is displayed on the LCD and the respective channel is muted.

If the pin assignment of the used wiring differs from the d&b standard, "TSM Detection" can be set to "off" in order to avoid the detection of an error.

## 2.5 Display messages

### 2.5.1 Error messages

Error messages can be related either to the device ("Device") or to a single or both channels of the device ("Channel"). Channel related error messages are supplemented by the channel information.

<b>Device</b>	<b>System Error [nnn]:</b> an internal fault has occurred. Switch the device off and on again (reboot). The number [nnn] can provide your d&b service partner with information on the cause of the fault.
<b>Device</b>	<b>Program Error [nnn]:</b> a fault has occurred in the control processor. Switch the device off and on again (reboot).
<b>Device</b>	<b>PS Overvoltage ([xxx] V):</b> mains overvoltage. The actual voltage value that causes the message is displayed. The device switches to standby mode.
<b>Device</b>	<b>PS Undervoltage ([xxx] V):</b> mains undervoltage. The actual voltage value that causes the message is displayed. The device switches to standby mode.
<b>Device</b>	<b>PS Error [nnn]:</b> a fault has occurred in the switched mode power supply. The number [nnn] can provide your d&b service partner with information on the exact cause of the fault.
<b>Device</b>	<b>PS Temp. Warn. ([xx] °C):</b> the temperature of the Power Supply is very high, the air flow should be checked (fan filter) or the load should be reduced.
<b>Device</b>	<b>PS Overtemp. ([xx] °C):</b> the temperature of the Power Supply is too high and the device is muted and the loudspeaker output is switched off. After cooling down to a permitted operating temperature the device will switch on automatically.
<b>Device</b>	<b>Remote Error [nnn]:</b> a fault has occurred in the remote control connection. This error message may appear if remote control is selected but no network is connected or no other device is found on the network.
<b>Channel</b>	<b>Invalid DSP Program:</b> the operating software for the DSP(s) is not present or contains errors. The device switches to mute. Switch the device off and on again (reboot). If the fault recurs, consult your d&b service partner.
<b>Channel</b>	<b>Invalid Speaker Data:</b> the DSP data of the loudspeaker configuration selected is not present or contains errors. The device switches to mute.
<b>Channel</b>	<b>DSP Error [nnn]:</b> an error has occurred in the digital signal processor(s) (DSP(s)), the device switches to mute. Switch the device off and on again (reboot). The number [nnn] can provide your d&b service partner with information on the cause of the fault.
<b>Channel</b>	<b>Amp. Error:</b> an internal fault has occurred in the amplifier(s), the device switches to mute and the loudspeaker output is switched off. The device does not contain any user serviceable components, it must be returned to a d&b service partner.
<b>Channel</b>	<b>Amp. Protect:</b> output current too high, possibly caused by a short circuit or fault in a loudspeaker cable or another low impedance condition. The device is muted and the loudspeaker output is switched off. Once the cause of the fault has been identified and removed, the device has to be switched to standby mode (long press on MUTE A switch) to clear the error status.

- Channel**      **Amp. Temp. Warn. ([xx] °C):** the temperature of the heat sink is very high, the air flow should be checked (fan filter) or the load should be reduced.
- Channel**      **Amp. Overtemp. ([xx] °C):** the temperature of the heat sink is too high and the device is muted and the loudspeaker output is switched off. After cooling down to a permitted operating temperature the device will switch on automatically.
- Channel**      **Amp. Temp Err. ([xx] °C):** the temperature of the heat sink of the device is too high. The device is muted and the loudspeaker output is switched off. After cooling down to a permitted operating temperature the device will switch on automatically.
- Channel**      **Top/Sub-Mismatch:** In conjunction with the "Dual channel mode" a TOP cabinet is connected to a SUB configured channel.

### 2.5.2 System Check, Load and Input Monitoring

During the calibration procedure of the System Check and Load Monitoring function the following error messages may appear:

- Device**      **Power is off:** the device is in Standby mode and a calibration is not possible.
- Channel**      **Amp is muted:** the respective channel of the device is muted and a calibration is not possible.
- Channel**      **Current too low:** the pilot signal level was increased to the maximum, but a sufficient current has not been reached. Check connections and wiring.
- Channel**      **Current too high:** the maximum current was exceeded at minimum pilot signal level. Check the wiring for short circuits.
- Channel**      **Cancelled (by User):** the user has interrupted the calibration either locally or remotely.

### 2.5.3 Error messages during operation

During operation the following error messages related to Load Monitoring (LM) and Input Monitoring (IM) may appear:

**Note:** If both Load and Input Monitoring are activated and if both detect an error, Load Monitoring obtains the highest priority and therefore only the error messages related to Load Monitoring are displayed.

- Channel (LM) SpkrFault ([xxΩ/xxΩ]):** both LF and HF paths of the connected loudspeaker have failed or the loudspeaker has been disconnected. The display shows the value (ohms) that caused the error.
- Channel (LM) SpkrFault LF ([xxΩ]):** the LF path of the connected loudspeaker has failed. The display shows the value (ohms) that caused the error.
- Channel (LM) SpkrFault HF ([xxΩ]):** the HF path of the connected loudspeaker has failed. The display shows the value (ohms) that caused the error.
- Channel (IM) Input Monitoring Fault:** an Input Monitoring error has occurred, e.g. the detection of an incoming pilot signal has failed. This message applies to all operating modes of Input Monitoring.

#### 2.5.4 Further messages

The following messages are intended for information on the status of the D12. They are no error messages.

**Standby:** indicates that the device is in standby mode.

**Unlock: Press knob 2s:** indicates that the device has been locked to protect it against accidental or unauthorized operation. Press and hold the encoder for a minimum of 2 seconds until "Lock" disappears from the lower status line of the LCD.

### 2.6 System Reset

**Note:** Following a system reset operation all user settings of the device are lost except for the "dbCAN Id".

- Switch off the unit.
- Press and hold the MUTE A switch while switching on the power supply to the unit again.

The following "Reset screen" is displayed:

**All Settings have been  
reset to factory defaults  
Press A again to reboot  
dbCAN active Id 0.01**

- Release the MUTE A switch and press the MUTE A switch again. The unit will restart and is ready for operation.

### 3. D12 Firmware update

**Note:** A firmware update erases all user settings of the device. The device name and the log files are kept.

The operating software – firmware – can be updated in two different ways.

1. Firmware update of a single amplifier via serial interface using the dbUpdate software program.
2. Firmware update of multiple amplifiers via the d&b Remote network (CAN-Bus) using the R10 Service software.

In addition, the d&b Firmware Installer is required.

All required software packages can be downloaded from the d&b website at: [www.dbaudio.com](http://www.dbaudio.com).

#### 3.1 Firmware Installer

The Firmware Installer is a software program used to archive the firmware files for the d&b amplifiers to a desired directory on your computer. During the update procedure these firmware files are accessed either by D6-D12-dbUpdate or R10.

#### 3.2 D12 Firmware update via D6-D12-dbUpdate

D6-D12-dbUpdate is a control software for loading new firmware and/or loudspeaker setups onto the D12 Amplifier.

To execute a firmware update the computer must be fitted with an RS 232 interface (serial port) and a RS 232 extension cable must be used (D-SUB 9 f/m cable with one to one connections between pins 2, 3 and 5).

Pin	Signal	Remark
2	RxD	
3	TxD	
5	GND	Signal ground

**Tab. 5: D-SUB 9 pin assignment on d&b devices**

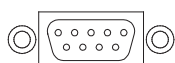
Please refer to the computer manual for the pin configuration of an RS 232 port that uses a D-SUB 25 connector.

#### 3.3 D12 Firmware update via CAN-Bus and R10

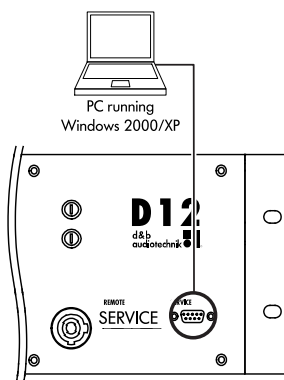
Using the d&b Remote network and the R10 Service software a firmware update can be carried out via CAN-Bus. R10 allows to update the firmware of multiple devices connected to the network at one time.

**Notes:** For further information on R10 and the firmware update via CAN-Bus please refer to the R10 manual.

A detailed description of remote control via CAN-Bus is given in the technical information TI 312 (d&b code D5312.E).

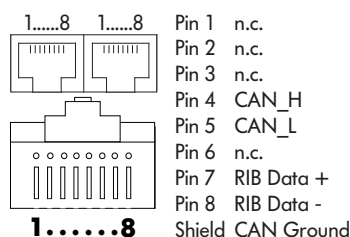


**Fig. 9: SERVICE connector (D-SUB 9)**



**Fig. 10: 1:1 RS232 connection between D12 and PC**

## 4. Remote control & monitoring



**Fig. 11: Pin assignment for remote control (RJ45)**

The D12 is fitted with a two-wire serial remote control interface, (2 x RJ 45) carrying both the RIB and CAN-Bus signals. All pins of both connectors are wired in parallel allowing either to be used as the input or output. Where remote control networking conforms to a "Bus or Ring topology" one connector is used for the incoming signal and the second connector allows for direct connection to another device or for terminating in case of a CAN-Bus network. The interface connections for the RIB (pin 7/8) are opto-coupled, while the connections for the CAN-Bus (pin 4/5) are hard wired to common ground (protective earth).

### 4.1 Remote-Mode "dbCAN"

All functions of the D12 can be remotely interrogated via the dbCAN (CAN-Bus).

**Note:** A detailed description of remote control via dbCAN (CAN-Bus) is given in the technical information TI 312 (d&b code D5312.E)

### 4.2 Remote-Mode "RIB"

The D12 can be remotely interrogated via the d&b Remote Interface Bridge (RIB). Please refer to the RIB Object address table below.

Address	Read/Write	Object	Bit 6	Bit 5	Bit 4	Bit 3	Bit 2	Bit 1	Bit 0	
			Binary: 2 <sup>6</sup> Val: 64	Binary: 2 <sup>5</sup> Val: 32	Binary: 2 <sup>4</sup> Val: 16	Binary: 2 <sup>3</sup> Val: 8	Binary: 2 <sup>2</sup> Val: 4	Binary: 2 <sup>1</sup> Val: 2	Binary: 2 <sup>0</sup> Val: 1	
0	R	Status Base Device		Gen-Error	SW-Rem	LockCmd	LockMode	PWR Ok	PWR On	
0	W	Status Base Device				LockCmd			PWR On	
1	RAW	Switch Settings 2		Setup_B_4	Setup_B_3	Setup_A_4	Setup_A_3	Delay On B	Delay On A	
2	RAW	Potentiometer A	Attenuation in steps of 0.5dB, 7-bit coded (0=+6dB, 127=-57.5dB)							
3	RAW	Switch Settings A	MUTE	Setup_Bit2	EQ A	Setup_Bit1	Setup_Bit0	Filter 2	Filter 1	
4	RAW	Potentiometer B	Attenuation in steps of 0.5dB, 7-bit coded (0=+6dB, 127=-57.5dB)							
5	RAW	Switch Settings B	MUTE	Setup_Bit2	EQ B	Setup_Bit1	Setup_Bit0	Filter 2	Filter 1	
6	RD/WR	Delay time coarse A	Delay in steps of 10 ms, 7-bit coded (max. 34 = 340 ms)							
7	RD/WR	Delay time fine A	Delay in steps of 0.1 ms, 7-bit coded (max. 127 =12.7 ms)							
8	R	Errors Base Device		Tmp Error	Tmp Warn	AMP Prot. B	AMP Prot. A	AMP Error B	AMP Error A	
9	RD/WR	Delay time coarse B	Delay in steps of 10 ms, 7-bit coded (max. 34 = 340 ms)							
10	R	Output Signal + EN60849						Present B	Present A	
10	W	Output Signal	EN-B-Bit1	EN-B-Bit0	EN-A-Bit1	EN-A-Bit0	Calib A+B**)			
11	RD/WR	Delay time fine B	Delay in steps of 0.1 ms, 7-bit coded (max. 127 =12.7 ms)							
12	RAW	LED's Controller A	ISP	GR	OVL		ImpErr A Hf	ImpErr A Lf	ImpErr A	
13	R	Headroom/GainRed A	0..63:Headroom, 64..127:GainRed, 7-bit coded (0=32dB Hdrm, 64=0dB, 127=31.5dB GR)							
14	RAW	LED's Controller B	ISP	GR	OVL		ImpErr B Hf	ImpErr B Lf	ImpErr B	
15	R	Headroom/GainRed B	0..63:Headroom, 64..127:GainRed, 7-bit coded (0=32dB Hdrm, 64=0dB, 127=31.5dB GR)							

**Tab. 6: D12 RIB Object address table**



